

CAD FILE:

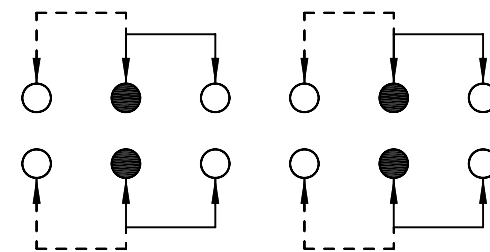

**SCHEMATIC (NON-SHORTING)**

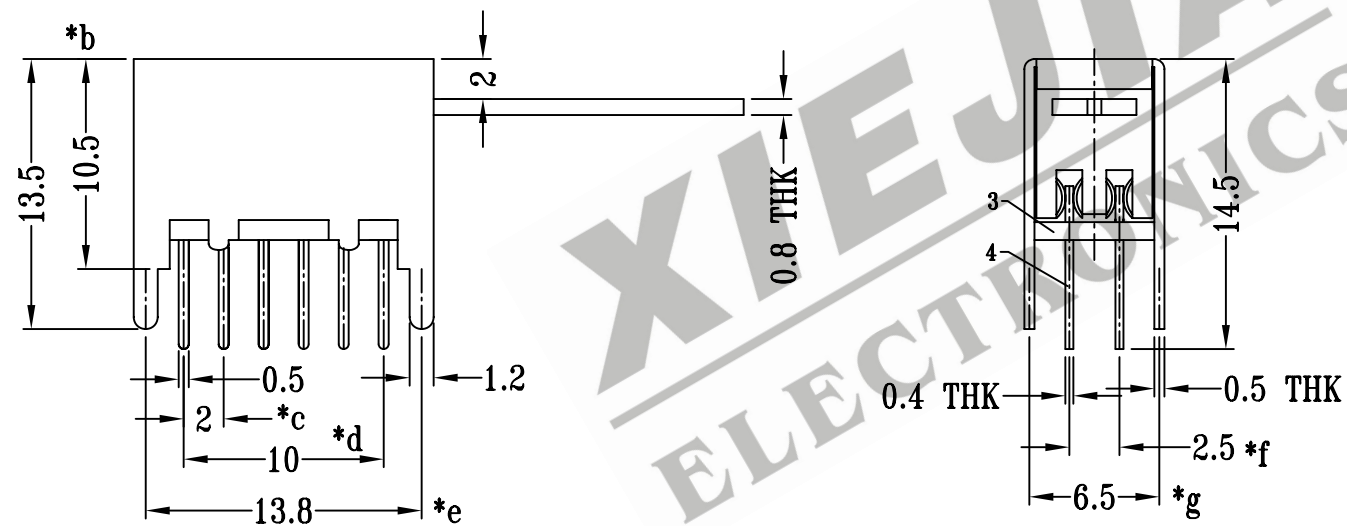
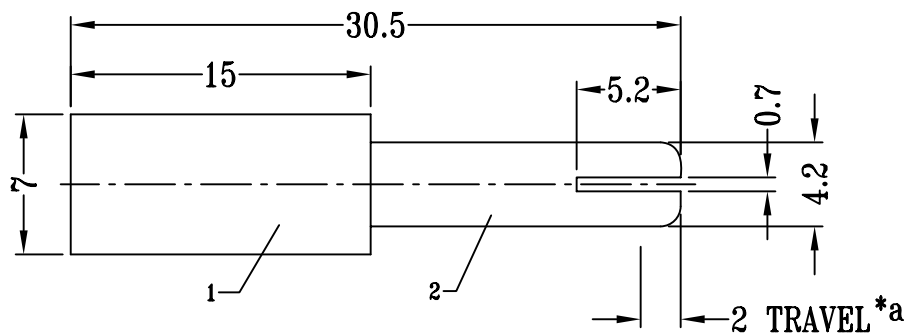
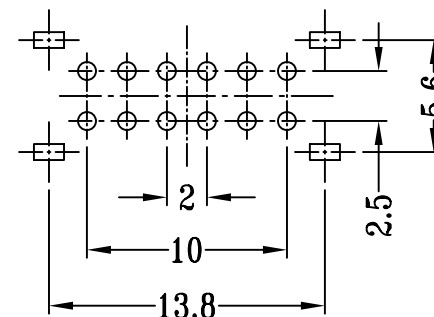

**P.C.B LAYOUT**

注：“\*”表示关键尺寸（7个）

8					TOLERANCE	SHENZHEN XIEJIA ELECTRONICS CO.,LTD.				
7	CONTACT CLIP	PBS	4	Ag CLAD	UNLESS SPECIFIED					
6	SPRING	STEEL WIRE	1	TEMPER	WITHIN: 1.5±0.1mm	ISSUE	DATE	DESCRIPTIONS		APPD.
5	SLIDER	POM	4	BLACK	OVER : 1.5±0.2mm					
4	TERMINAL	BRASS STRIP	12	Ag PLATED OVER Ni PLATED	TITLE : PUSH SWITCH	UNIT : MM		DRWG NO.: XJ-DR-PS42D06-00		
3	BASE	PHENOLIC RESIN	1	NATURAL	MODEL: PS-42D06	SCALE: 5:2		DWN.	ZHOUYU	2003-7-24
2	KNOB	STEEL STRIP	1	Ni PLATED	ALL MATERIALS MUST BE COMPLIANT TO ROHS	SCALE: 5:2		CHK'D	FANGYING	2003-7-24
1	FRAME	STEEL STRIP	1	Ni PLATED		APPD.	KANGXINAN	2003-7-24		
NO.	PART NAME	MATERIAL	Q'TY	FINISHING						